

# ELECTRIC RACER – BASIC BUILD

Name: \_\_\_\_\_ Set: \_\_\_\_\_ Date: \_\_\_\_\_

This guide will take you through the process of creating a basic electric racer. After you finish this build, you should be able to experiment, design and engineer your own racer.







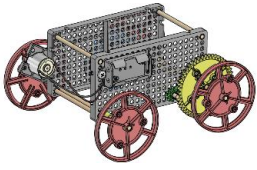



## Materials included in TeacherGeek Racer Packs:

Component colors may be different then shown.

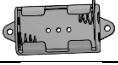
Component	Picture	# in 10 Pack	# For a Single Racer	# Required to Build Example Racer	# Extra -To Innovate Your Own Design
Strips		40	4	0	4
Dowels		80	8	4	4
Blocks		40	4	2	2
Hole Plates		20	2	2	0
Slide Stop 30cm		3	7.5cm (3in)	1.5cm	6cm
#10 Screws		80	8	3	5
#10 Nuts		80	8	3	5
Rubber Bands		~100	~10	1	~9
70mm Pulleys		10	1	1	0
55.5mm Pulleys		10	1	0	1
25.5mm Pulleys		10	1	0	1
9mm Pulleys		10	1	1	0
50 Tooth Gears		10	1	1	0



# ELECTRIC RACER – BASIC BUILD

Component	Picture	# in 10 Pack	# For a Single Racer	# Required to Build Example Racer	# Extra -To Innovate Your Own Design
40 Tooth Gears		10	1	0	1
20 Tooth Gears		10	1	0	1
10 Tooth Gears		10	1	1	0
Wheels		40	40	0	0
Rubber Band Tires		40	4	2	2
Battery Holders		10	1	1	0
Project Motors		10	1	1	0
Angle Brackets		20	2	0	0
Motor Mounts		10	1	1	0
Stop Clips		40	4	1	3
Motor Adaptor Pins		15	1	1	0

## Other Materials:

Two AA batteries are required per racer, but not included in the kit.





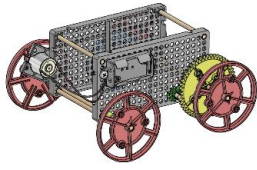

The TeacherGeek system is designed to be used with other materials you can find (materials not supplied in the TeacherGeek pack). Other materials could be craft supplies, from a recycling bin, wood, metal, cardboard, or anything else you may have. These materials can be used to help you create your own unique designs.





# ELECTRIC RACER – BASIC BUILD

## Tools Required:

Tool	Picture	Use	# Required	# Suggested for Classes	Alternate
Reamer		Enlarge holes so dowels slide & rotate	1	1 for every 3-4 students	Drill bit and drill
Multi-Cutter		Cut wood, plastic, cardboard	1	1 for every 3-4 students	Side Cutters, Saw, Pruning Shears
Pliers		Tighten nuts, pull out dowels	1 -Optional	1 for every 3-4 students	Wrench
Phillips Screwdriver		Tighten screws	1	1 for every 3-4 students	
Crayon or Wax		Rub on dowel to make it slide easier into a hole	1 -Optional	1 for every 3-4 students	Wax
Safety Glasses		Protect eyes	1	1 per student	

Age Level Recommendation: 12 and above

Wear safety glasses when building and testing your racer.

## Construction:

Dowels and Strips can be cut with a multi-cutter (best method), saw, side cutters or pruning shears. Wear safety glasses when cutting.



Tip: Rub a dowel with soap, wax or a crayon to allow it to slide easier into and out of holes.

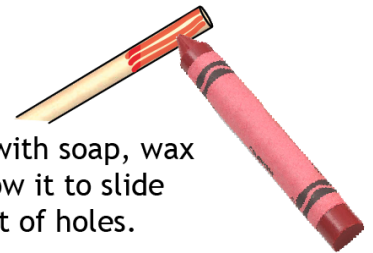

Push dowels into holes by:

1. Wiggling and pressing with your hands
2. Tapping dowels with a hammer or the side of your cutter.

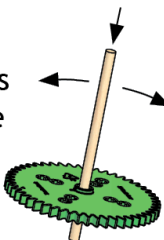

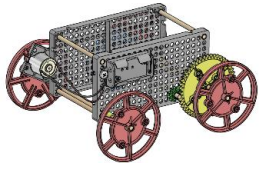

# ELECTRIC RACER – BASIC BUILD

## Step #1

Cut four 12cm (4 in) dowels.

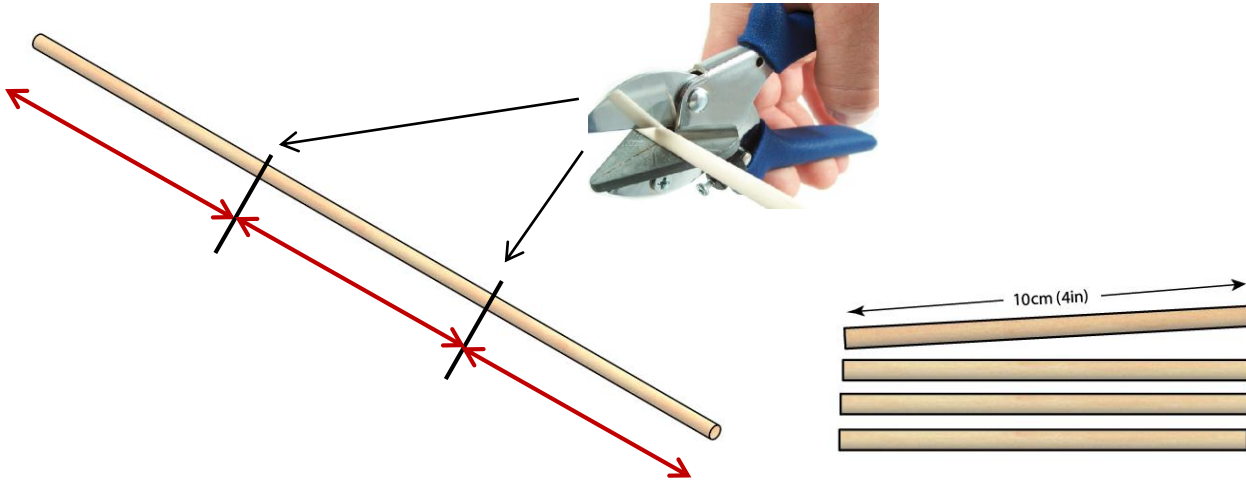

## Step #2

Press/tap the 12cm (4in) dowels into a hole plate.

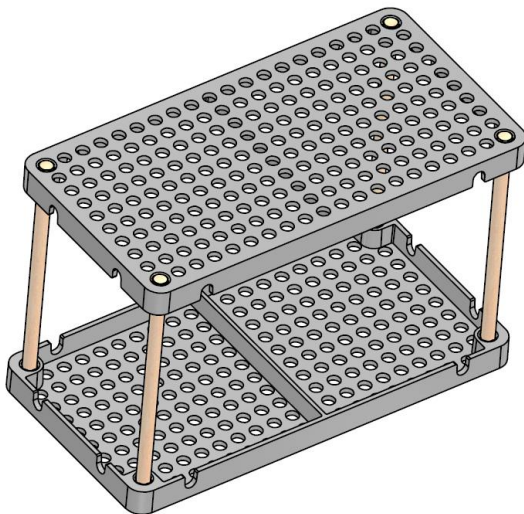
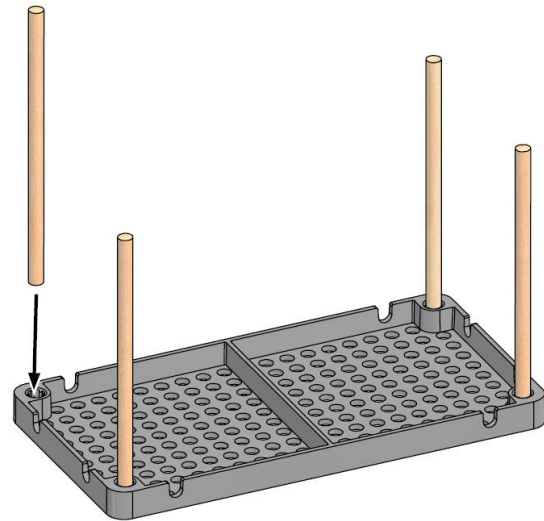

## Step #3

Push/tap a second hole plate onto the dowels. This creates the frame for your racer.

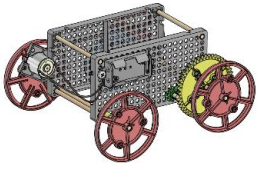

# ELECTRIC RACER – BASIC BUILD

## Step #4

Cut off an adaptor pin.

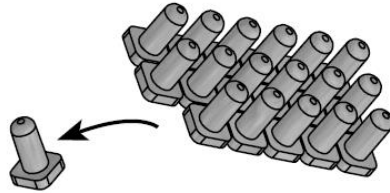

## Step #5

Tap or push the motor shaft into the adaptor pin. **Warning:** Only push/tap on the back of the motor shaft. Pushing from the sides of the motor could cause the motor to fall apart.

Tip: Place the adaptor pin into a perpendicular block to hold it while tapping the motor shaft in.

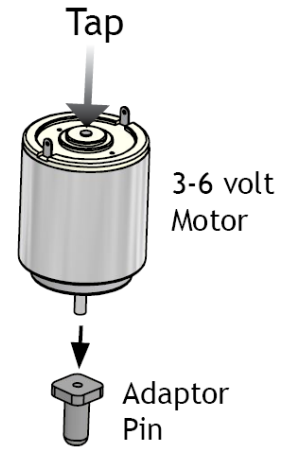

## Step #6

Place the motor into a mount.

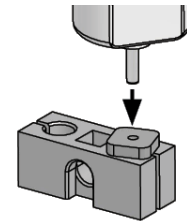
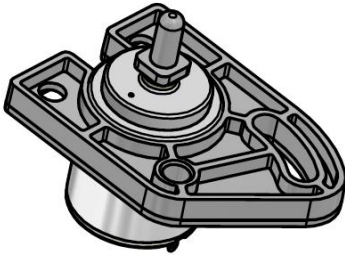

## Step #7

Use a screw and nut to fasten the motor mount to the frame.

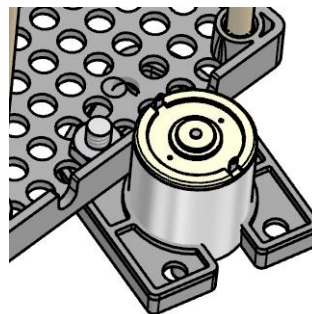
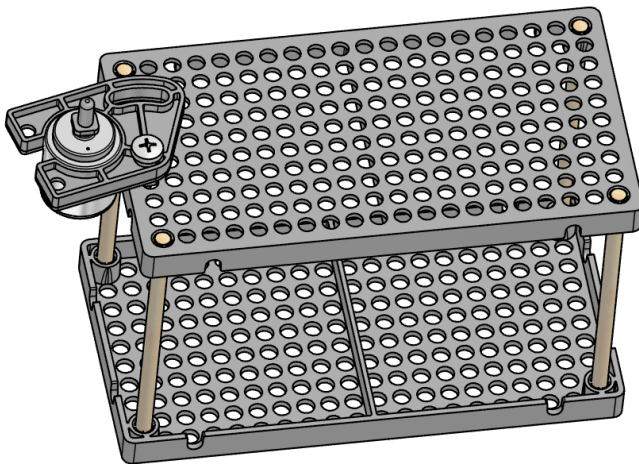



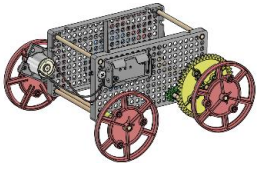

# ELECTRIC RACER – BASIC BUILD

## Step #8

Cut V shaped notches on the battery holder tabs.

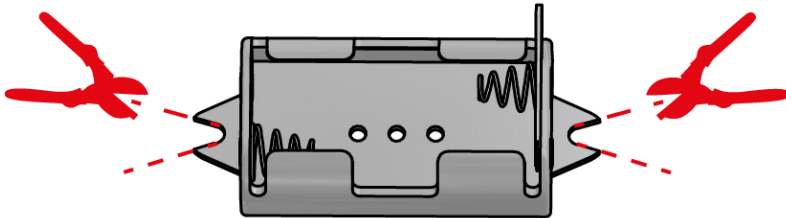

## Step #9

Use two screws and nuts to attach the battery holder to the frame.

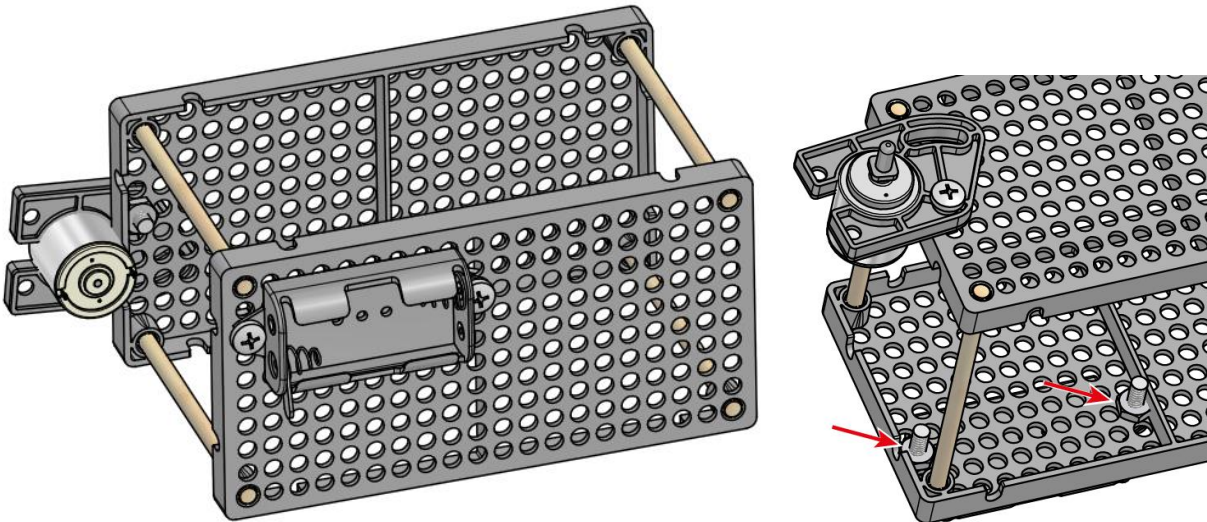

## Step #10

Connect the wires from the battery holder to the motor terminals. Twist the stripped wires around the motor terminals to help them stay on.

Tip: Strip more insulation off the wire ends. Use the additional exposed wire to twist around after feeding through the motor terminal.

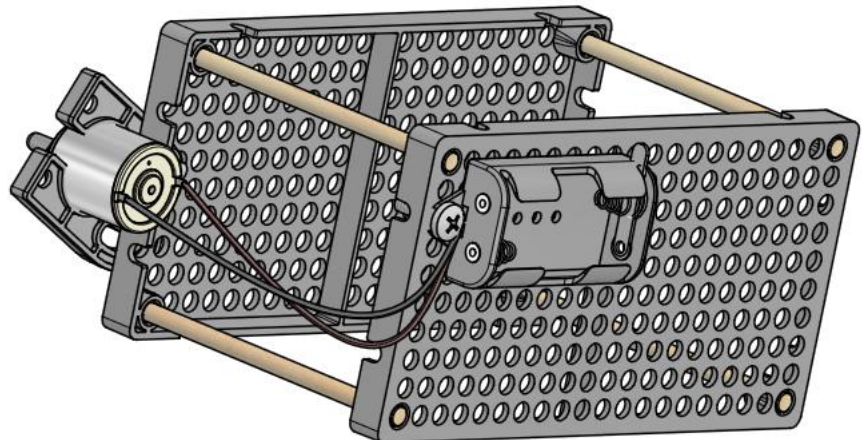

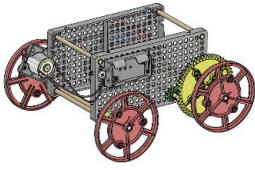

# ELECTRIC RACER – BASIC BUILD

## Run the motor

Place two AA batteries into the battery holder. Use the lever switch on the battery holder to turn the motor on and off. If the motor does not run, check the wires connected to the motor terminals. Make sure that the metal wires are touching the metal terminals.

Reversing Polarity: What happens if you switch the wires on the motor terminals?

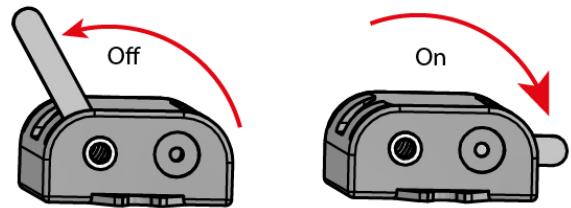

## Step #11

Cut a 140mm (5 1/2in) dowel and tap it into the largest pulley. The colors of your pulleys may be different than pictured.

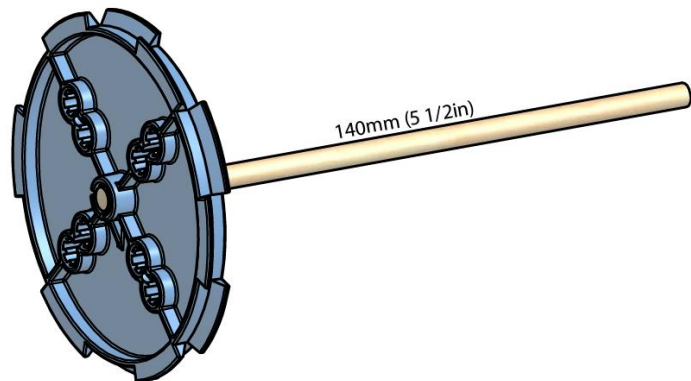

## Step #12

Cut a 15mm (5/8in) section of slide stop. Slide it down the dowel, next to the pulley.

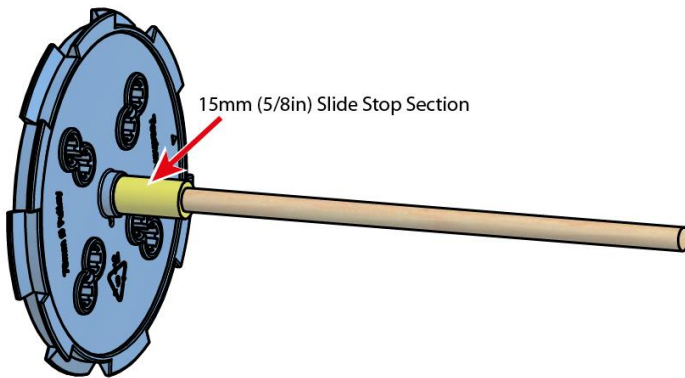

## Step #13

Place the assembly from Step #12 into the frame holes shown.

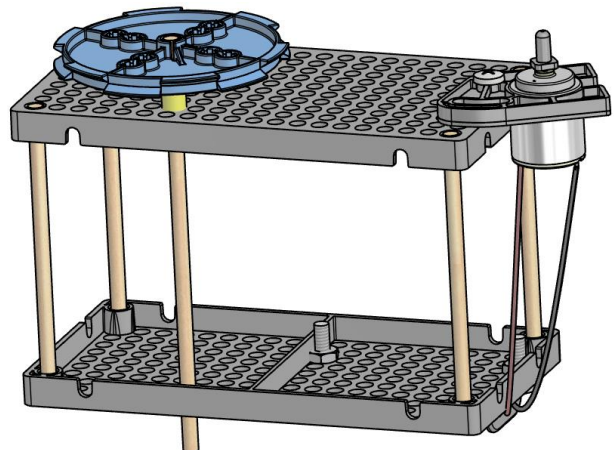

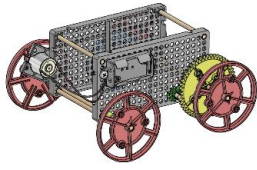

# ELECTRIC RACER – BASIC BUILD

## Step #14

Place a small pulley onto the motor pin. Your small pulley may be a different color.

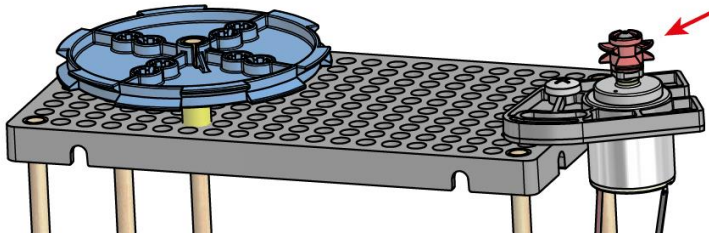

## Step #15

Wrap a small rubber band around the pulleys.

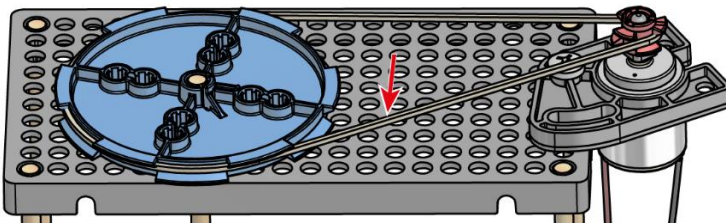

## Pulleys & Mechanical Advantage

Place a mark (with a pencil or pen) on the face of your pulleys. Rotate one of the pulleys all the way around. How far did the other pulley turn? Switch the pulleys around. Exchange them for a different size. Rotate them again. What happens? Pulleys can trade force for distance, or distance for force:

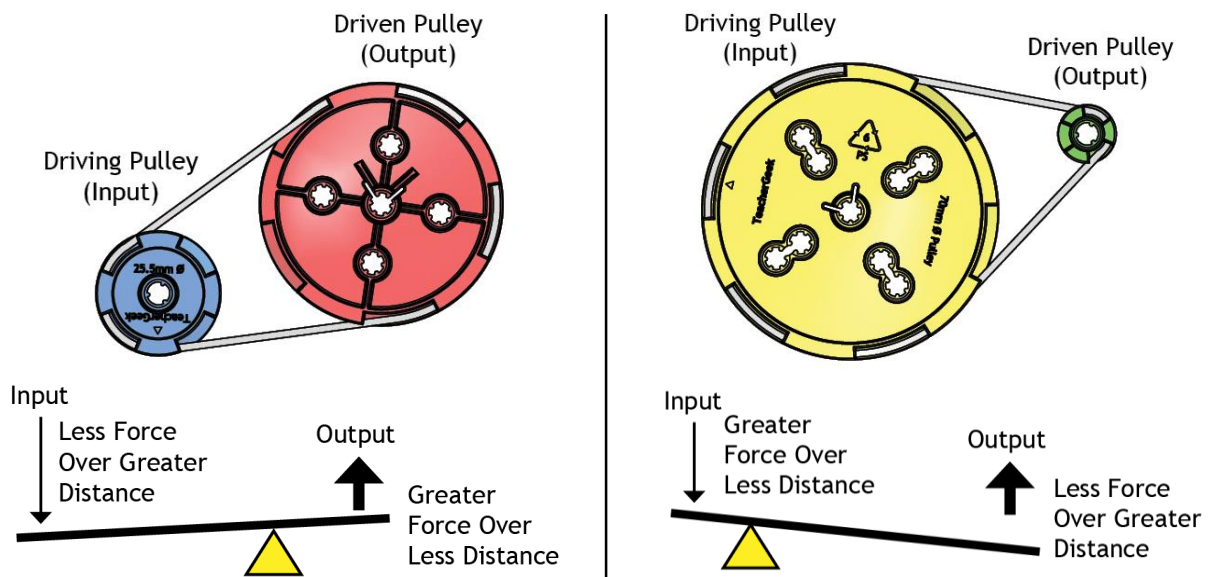

$$\frac{\text{Torque}_{\text{out}}}{\text{Torque}_{\text{in}}} = \frac{\text{Input Pulley Radius}}{\text{Output Pulley Radius}} = \frac{\text{Driving Pulley RPM (Distance}_{\text{in}})}{\text{Driven Pulley RPM (Distance}_{\text{out}})}$$



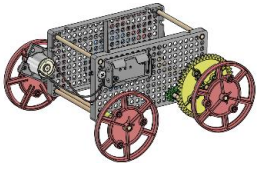

# ELECTRIC RACER – BASIC BUILD

## Step #16

Place the smallest gear onto the pulley dowel.

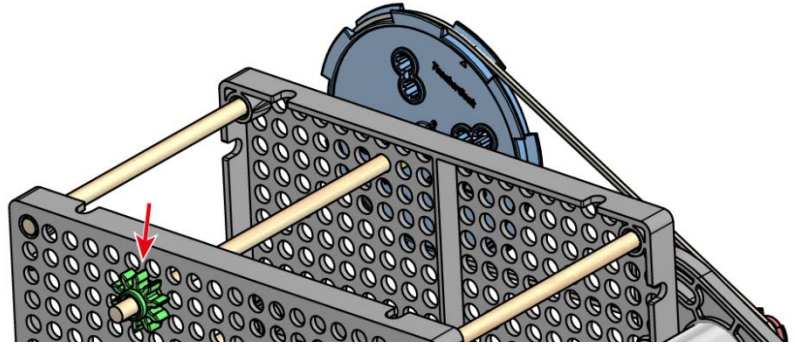

## Step #17

Cut a 200mm (7 7/8in) dowel. Tap the dowel through a large, 50 tooth gear, so it sticks out 40mm (1 9/16in)

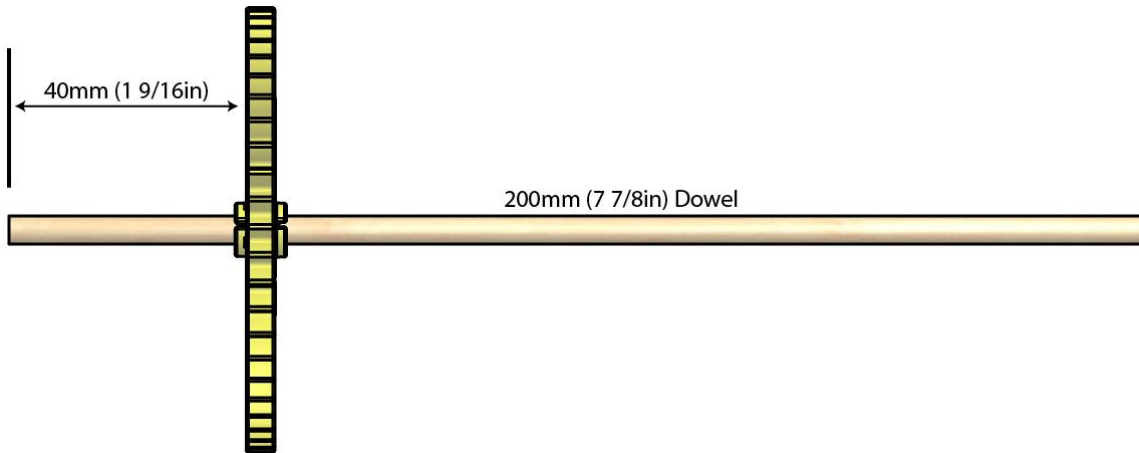

## Step #18

Place the assembly from Step #17 into the frame, so the small and large gears mesh.

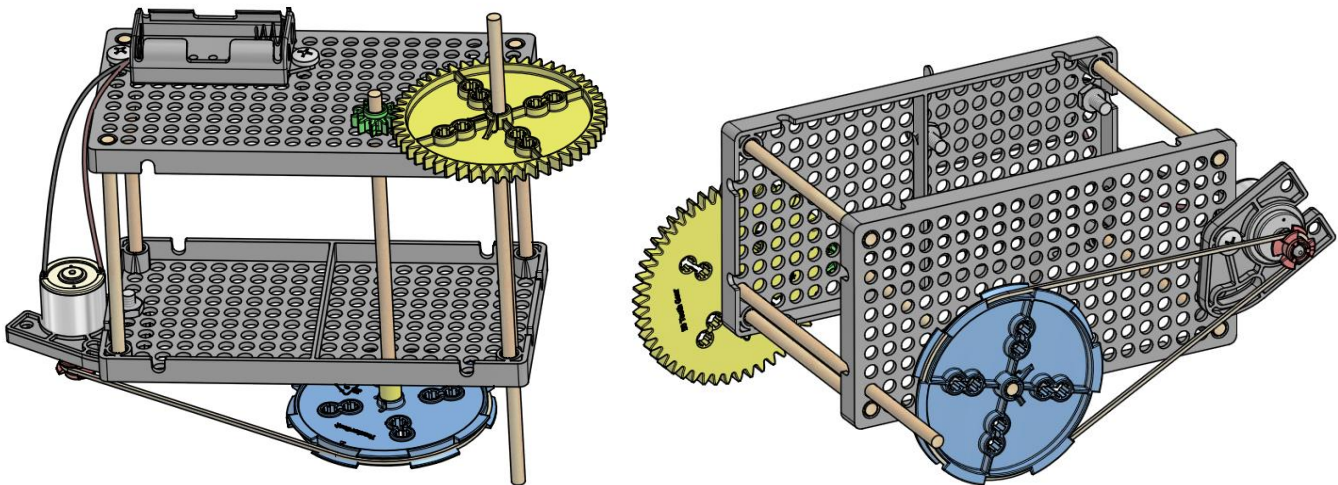

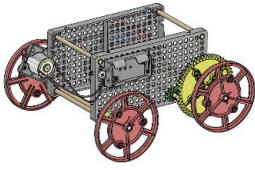

# ELECTRIC RACER – BASIC BUILD

## Step #19

Use a stop clip (pictured), or a section of slide stop to keep the dowel with the large gear from sliding out.

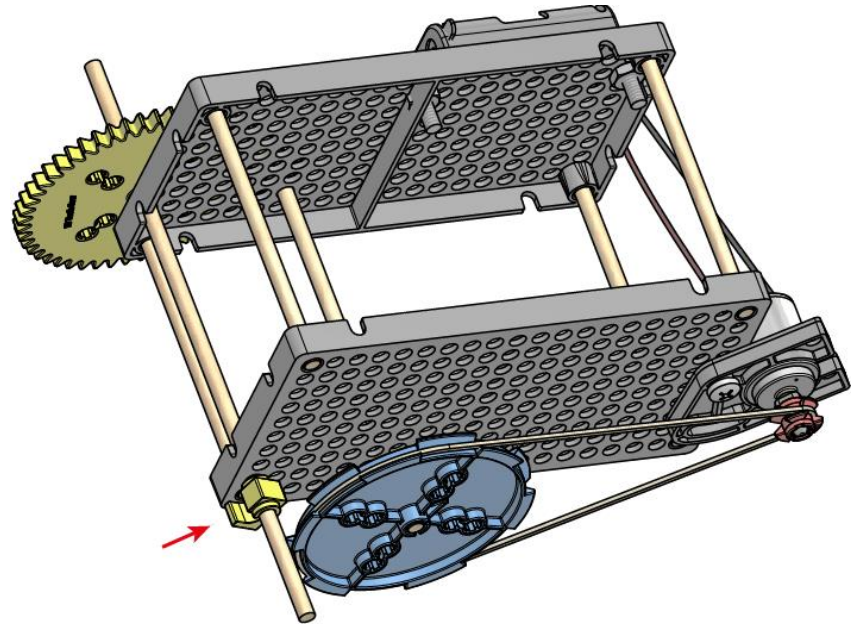
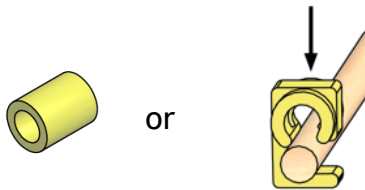

## Gears & Mechanical Advantage

You may want to change your gears and pulleys on your racer to make it faster or stronger. In that case, you need to know that gears work much like pulleys; trading force for distance or distance for force.

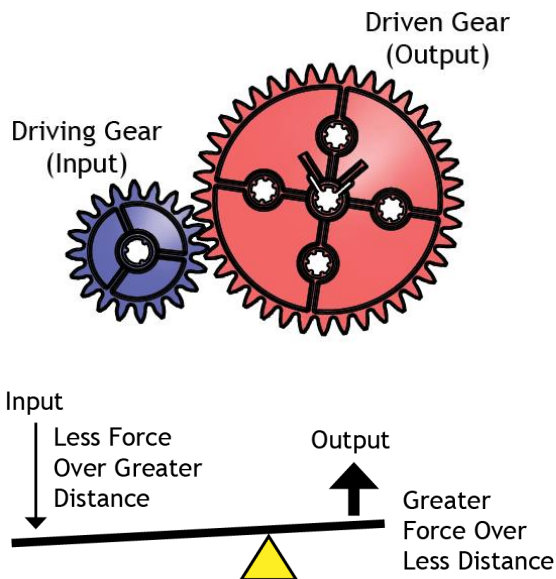

$$\frac{\text{Torque}_{\text{out}}}{\text{Torque}_{\text{in}}} = \frac{\# \text{ of Teeth on the Driving Gear}}{\# \text{ of Teeth on the Driven Gear}} = \frac{\text{Driving Gear RPM (Distance}_{\text{in}})}{\text{Driven Gear RPM (Distance}_{\text{out}})}$$

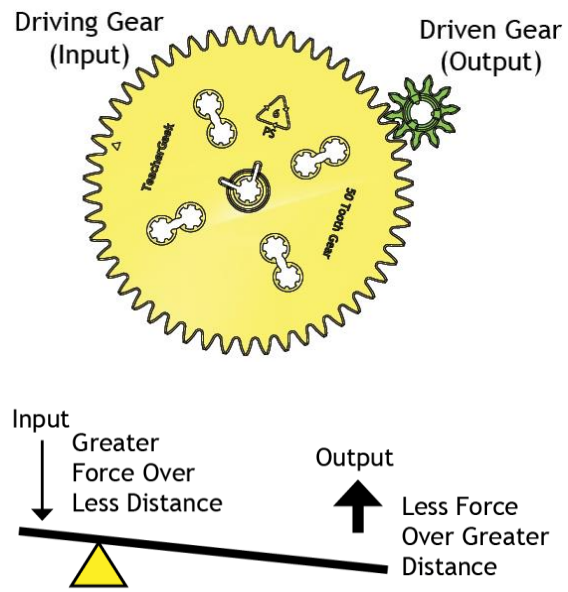

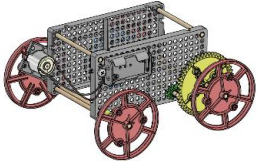

# ELECTRIC RACER – BASIC BUILD

## Step #20

Push/tap two wheels onto the ends of the dowel.

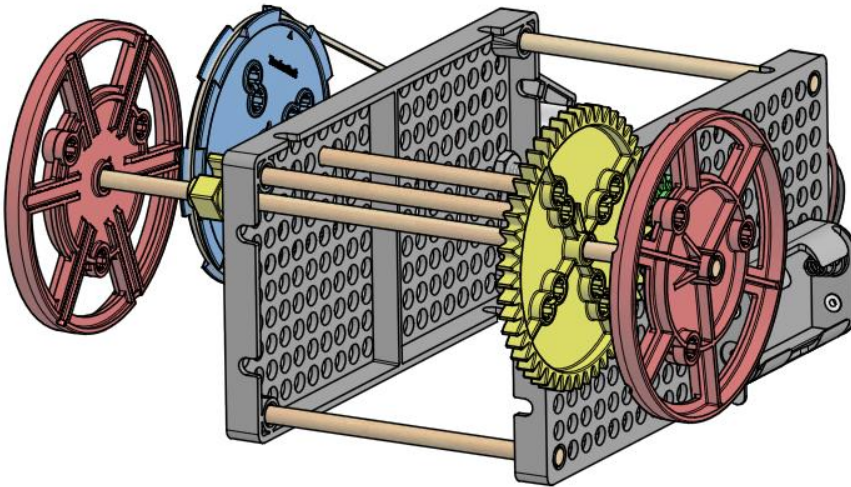

## Step #21

Cut a new 200mm (7 7/8in) dowel. Then cut two sections of slide stop. Use the slide stop, 200mm dowel and two wheels to make your racer roll.

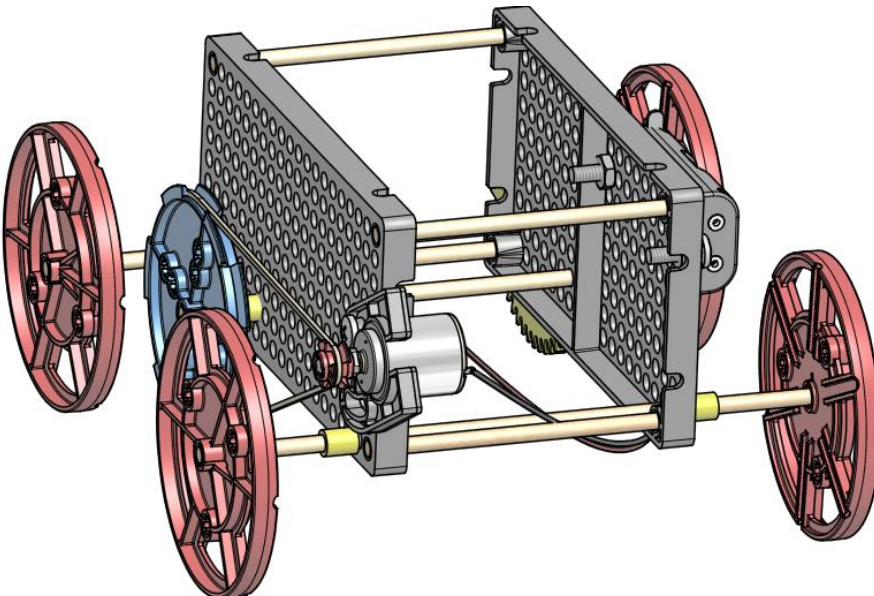



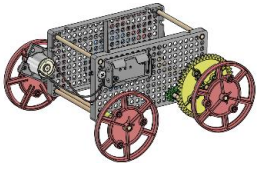

# ELECTRIC RACER – BASIC BUILD

## Step #22

Give your racer traction by wrapping large rubber bands around the wheels.

**Your example racer is done. It's ok, but you can make it much better...**

It is now time for you to re-engineer and evolve your racer. Extra components have been included to help you do this.

Ideas:

- Create a New Frame/Layout
- Develop Better Power Transfer (change the pulleys and gears)
- Add components (wood, metal, stuff from a recycling bin)
- Give it Personality
- Add a Solar Panel

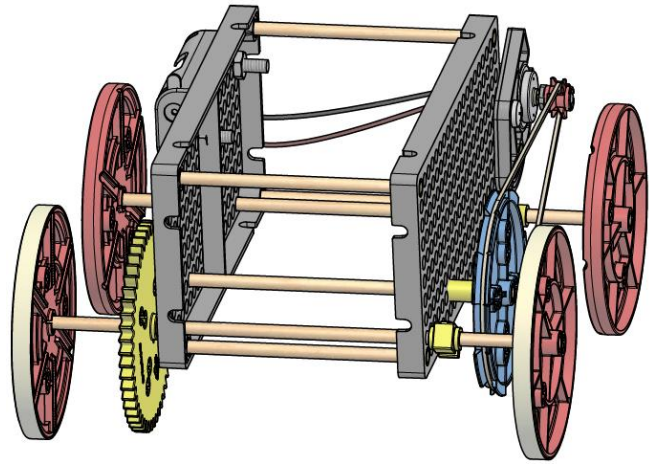

## Compound Gears and Pulleys

Multiple gears and pulleys can be linked to create a greater mechanical advantage. Experiment by changing the gears and pulleys on your racer.

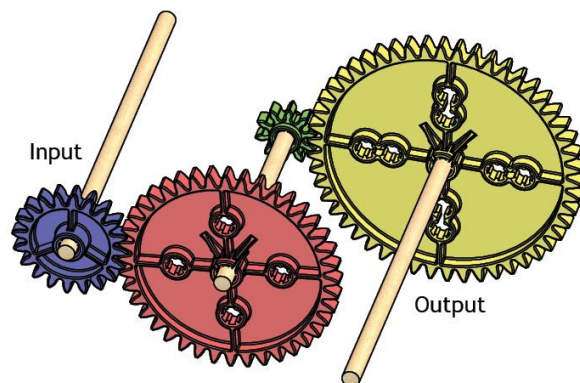
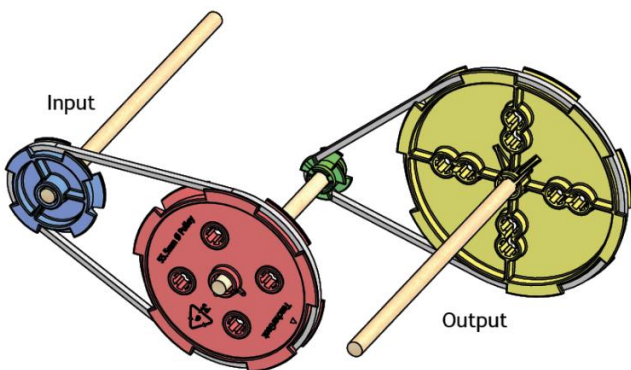
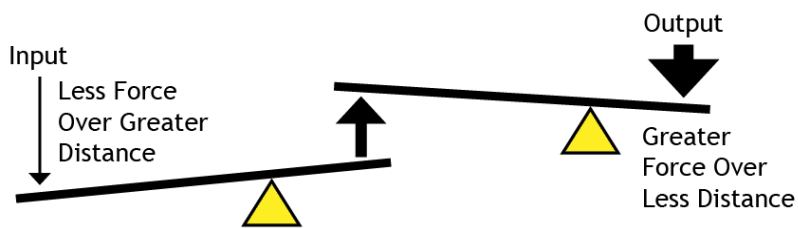



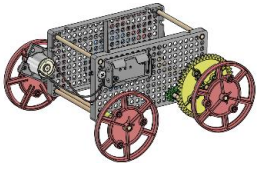

# ELECTRIC RACER – BASIC BUILD

## Extreme Challenges

Re-engineer your electric racer to compete in extreme challenges. Build it for one competition, then re-engineer it for another.

### Extreme Distance

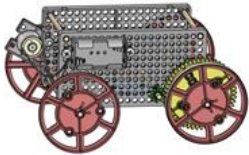

Slow & Far

### Dragster

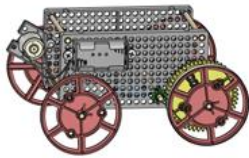

Short & Fast

### All-Terrain

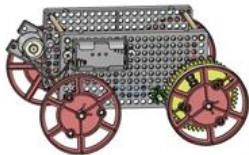

Over Terrain



### Precision Stop / Shuffleboard

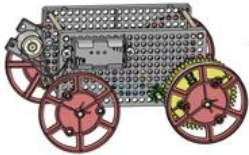

Precision Distance

No design is ever perfect.  
Continue to experiment, re-engineer and evolve  
your design.